

# PEMA A25 2D DRIVE UNIT

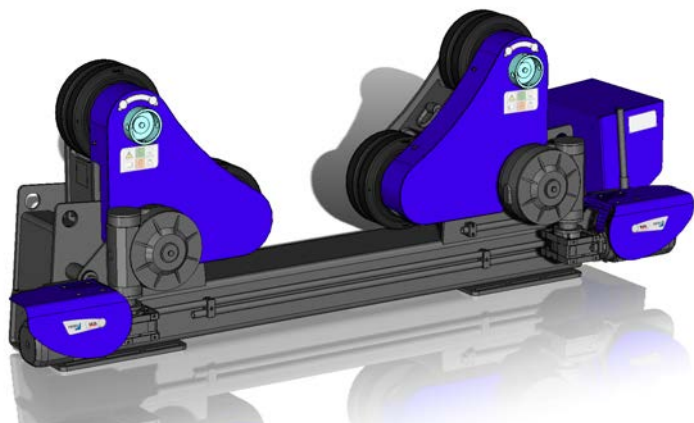

A SERIES | ROLLERBEDS



## Technical data

Max load (ton)	12,5
Rolling capacity (ton)	37,5
Max. rotation force (kN)	18
Rotation speed range (mm/min)	100-2000
Diameter range min-max 50% (mm)	700-5000
Diameter range min-max 100% (mm)	1500-5000
Roller diameter / total width (mm)	350 / 155
Rollers (pcs)	8
Roller material	PU
Width (mm)	780
Length (mm)	2870
Weight (kg)	950
Mains supply connection 50 Hz	3*400V+N+PE
Power (A)	16

Due to continuous R&D, Pemamek Ltd reserves the right to change the specification without notice.

## PEMA A series rollerbeds

The PEMA A-series of self-aligning roller beds is well-suited for managing unbalanced, thin-walled, and/or heavy cylindrical workpieces. These roller beds from the A-series ensure uniform weight distribution, consistent rotation speeds, and versatility across a broad spectrum of workpiece diameters, eliminating the necessity for separate adjustments. The loading capacities within the A-series span from 12 to 800 tons.

All four axles of PEMA A25 2D drive unit are power-driven. Four-wheel drive provides excellent grip and accurate rotation characteristics even for very unbalanced work-pieces.

In PEMA A-series rollerbeds, roller bogies automatically adjust to align with the diameter of the handled work-piece. Compared with other rollerbed types, PEMA A-type rollerbeds provide superior weight distribution. This is a significant advantage in handling of thin-walled work-pieces.

- **Ideal for unbalanced, thin-walled and/or heavy work-pieces**
- **Even weight distribution**
- **Automatic adjustment for different work-piece diameters**
- **PEMA rollerbeds fulfill the requirements of the European EN-safety norm**
- **All PEMA rollerbeds come with CE-markings**

### Better productivity

A cost-effective way to improve productivity, welding quality and safety.

### Easy integration

Easy to integrate with other PEMA products like column & booms.

### Reliable products

Designed and built for demanding machine shop environment.

# PEMA A25 2D DRIVE UNIT



A SERIES | ROLLERBEDS

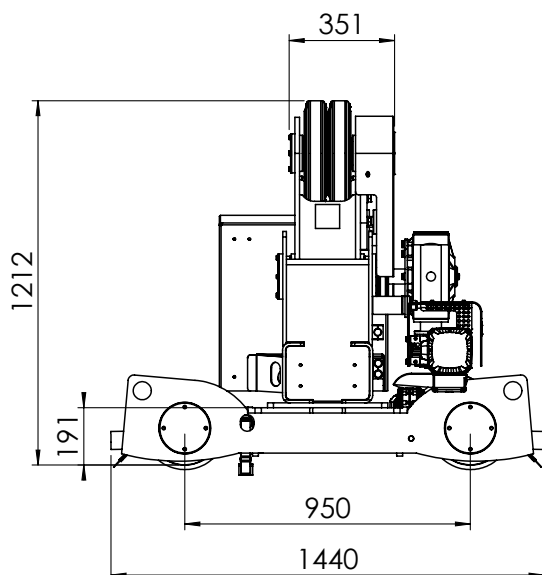
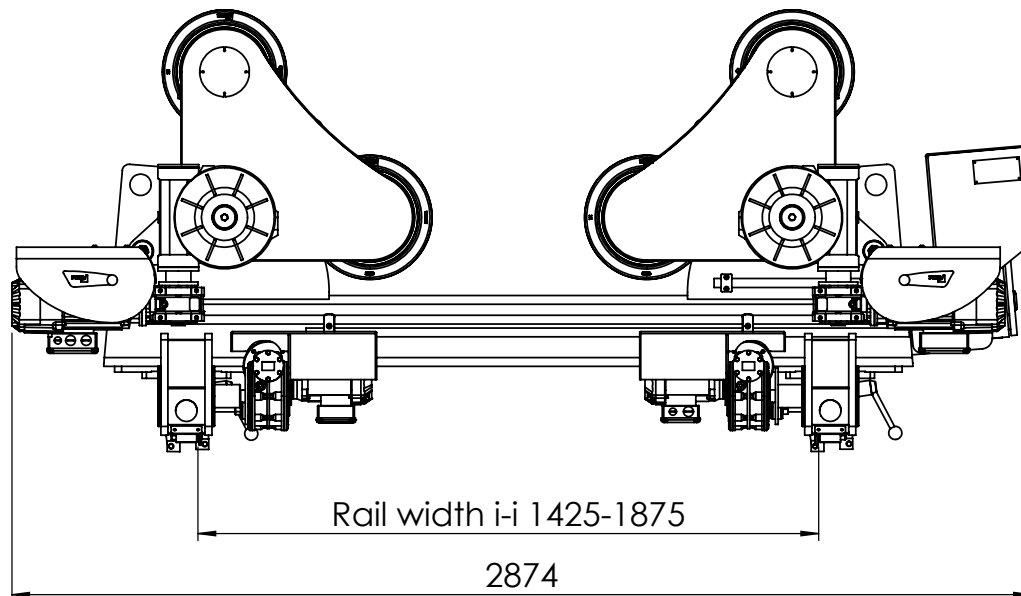

## Optional accessories

- Foot pedal for start/stop of rotation
- Foot pedal for speed control of rotation
- External control of rotation
- Rail car units

**PEMAMEK**  
THE WELDING AUTOMATION COMPANY

pemamek.com  
@pemawelding



General fabrication | Wind energy | Shipbuilding  
Heavy equipment | Power generation | Offshore and process equipment